

NOTES: UNLESS OTHERWISE SPECIFIED

- 1.0 SCOPE
 - 1.1 THIS SPECIFICATION DESCRIBES THE REQUIREMENTS FOR AN INCREMENTAL MODULAR ENCODER W/ ONCE AROUND PULSE MARKER.
- 2.0 MECHANICAL SPECIFICATIONS
 - 2.1 DIMENSIONS: SEE FIGURES 1 & 2 ON PAGE 2.
 - 2.2 MOUNTING REQUIREMENTS: SEE FIGURE 3 ON PAGE 2.
 - 2.3 TERMINATION: SEE TABLE 3
 - 2.4 MTG HARDWARE
 - 2.4.1 C2, H2: M2 OR #2-56 QTY 2.
 - 2.4.2 C4, H4: M2.5 OR #4-40 QTY 2.
 - 2.5 HUB BORE SIZE: SEE TABLE 2
 - 2.6 SHAFT END PLAY $\pm 0.010"$
 - 2.7 SHIPPING WEIGHT: 10 ENCODERS WITH TRAY = 10 oz.
 - 2.8 DISK MATERIAL: CHROME ON GLASS
- 3.0 ELECTRICAL SPECIFICATIONS
 - 3.1 CODE: INCREMENTAL AND ONCE AROUND PULSE MARKER
 - 3.2 PULSES PER REVOLUTION: SEE TABLE 1
 - 3.3 SUPPLY VOLTAGE: $5.0 \pm 5\%$
 - 3.4 CURRENT: 70 mA UNTERMINATED
 - 3.5 OUTPUT FORMAT: (SEE FIGURE 3)
 - 3.5.1 OUTPUT LOGIC LEVELS: LOGIC "1" 2.5 VDC MIN. LOGIC "0" .5 VDC MAX.
 - 3.6.2 OUTPUT TYPE: LD = 26LS31CD
VO = LM2901
VC = LM2901 WITH INTERNAL PULL UPS
 - 3.7 OPERATING FREQUENCY: 200 KHz
- 4.0 ENVIROMENTAL SPECIFICATIONS
 - 4.1 OPERATING TEMPERATURE: -10° TO 100° C.
 - 4.2 NON-OPERATING TEMPERATURE: -30° TO $+110^{\circ}$ C.
 - 4.3 HUMIDITY: 90% RELATIVE HUMIDITY (NON-CONDENSING)
 - 4.4 IP RATING : IP 40 WITH COVER

16	360
24	400
32	471
50	480
60	500
75	512
90	540
100	600
127	635
128	640
150	647
200	720
225	800
240	900
245	1000
250	1024
256	1250
300	2000
312	

HUB SIZE	\emptyset "A" $+0.01$ -0	SHAFT SIZE $+0$ -0.013
3/16"	4.757	4.754
4	4	3.997
5	5	4.997
6	6	5.997
1/4"	6.345	6.342
1/4+"	6.353	6.350
5/16"	7.932	7.929
8	8	7.997
3/8"	9.52	9.517
3/8+"	9.528	9.525

CA18			R24*	
PIN NO.	FUNCTION	COLOR	PIN NO.	FUNCTION
1	Vcc	RED	1	CH A
2	GND	BLK	2	Vcc
3	CH A	WHT	3	GND
4	CH A-	YEL	4	N/C
5	CH B	GRN	5	N/C
6	CH B-	BLU	6	N/C
7	INDEX	ORN	7	N/C
8	INDEX-	BRN	8	CH B
			9	N/C
			10	INDEX

* VC OR VO ONLY

SPECIFY	GATING
-0	UNGATED $360^{\circ} \pm 20\%$
-1	A&B $90^{\circ} \pm 45^{\circ}$

SPECIFY	CLOSURE OPTION
C2	M2 OR 2-56 MTG, NO HOLE COVER
H2	M2 OR 2-56 MTG, COVER WITH HOLE
C4	M2.5 OR 4-40 MTG, NO HOLE COVER
H4	M2.5 OR 4-40 MTG, COVER WITH HOLE

ORDERING INFORMATION

RM15 - XXXX - XXX - 5 - XXXX - XX - X - XX

RESOLUTIONS
SEE TABLE 1

HUB SIZE
SEE TABLE 2

CA18
R24

INDEX GATING OPTIONS
SEE TABLE 4

LD, VO, VC

CLOSURE OPTIONS
SEE TABLE 5

TO THE BEST OF OUR KNOWLEDGE THE RM15 IS RoHS COMPLIANT

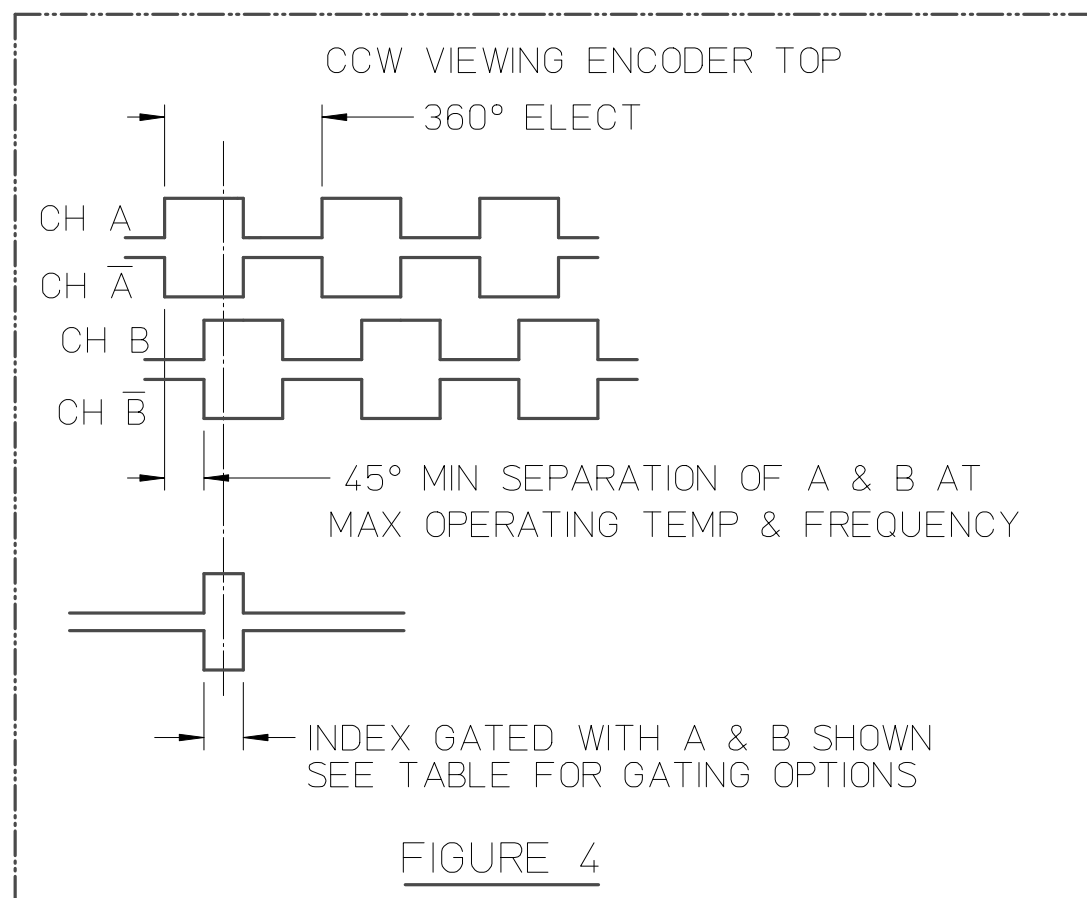

FIGURE 4

RELEASE # 39724	TEXT Initial release	RENCO ENCODERS INC. 26 COROMAR DR. GOLETA, CA. 93117	
This document is the property of Renco Encoders Inc. and is submitted in confidence. Disclosure, reproduction or publication without written authorization is prohibited.	DRAWN Cepeda 10/24/07	TITLE	
	APPV'D	Outline dwg, RM15	
	REL'D	SIZE FSCM NO. C 34479 DWG NO. 641499-00-A-01 VER [REV] SHT	
MAT'L FINISH	TOLERANCES UNLESS OTHERWISE SPECIFIED ALL DIMENSIONS ARE IN MILLIMETERS PER ISO 2768-c	SCALE NONE	THIS DWG PREPARED IN ACCORDANCE WITH: ASME Y14.5M -1994
THIRD ANGLE PROJECTION			PAGE 1 OF 2

NOTES: UNLESS OTHERWISE SPECIFIED

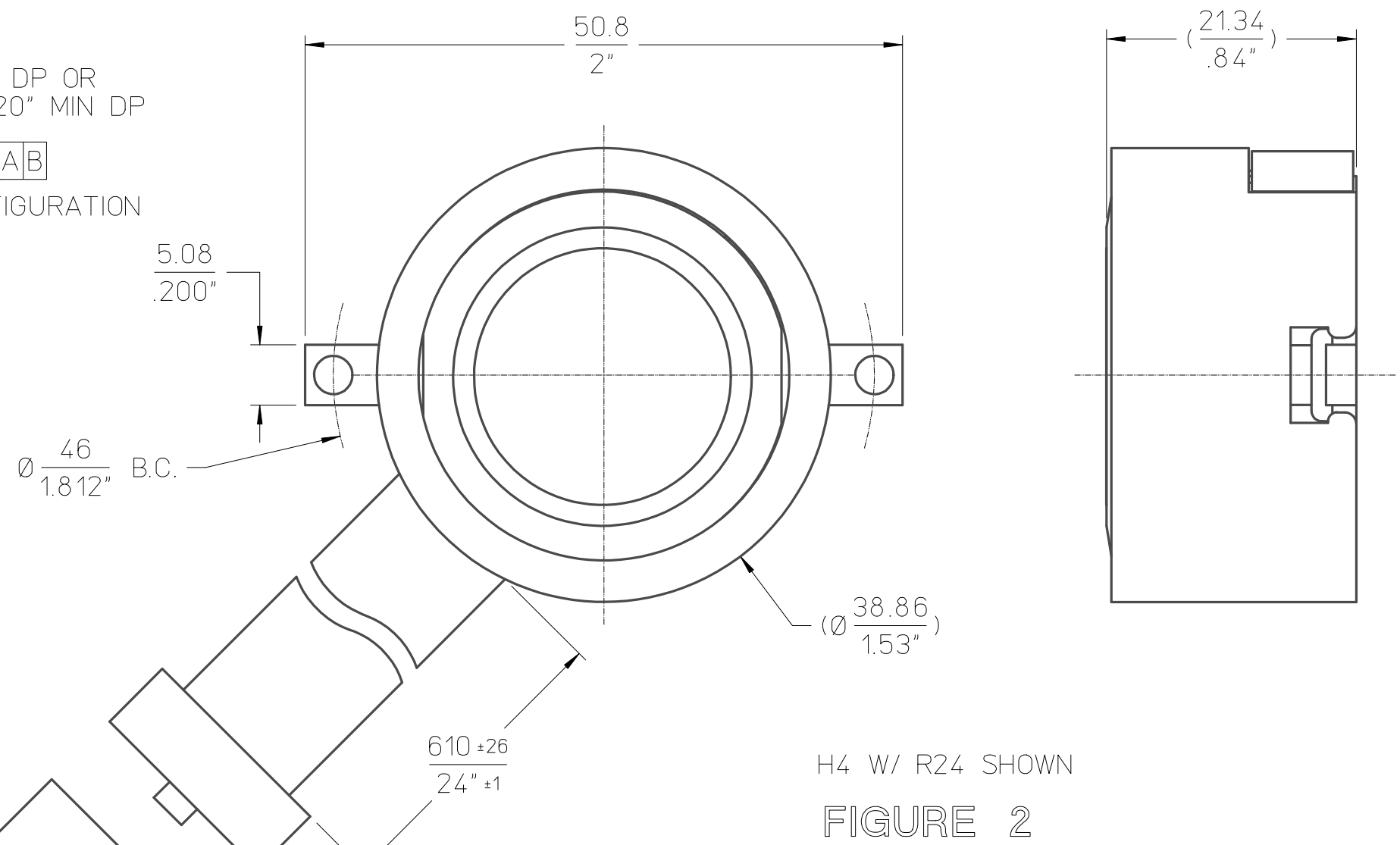
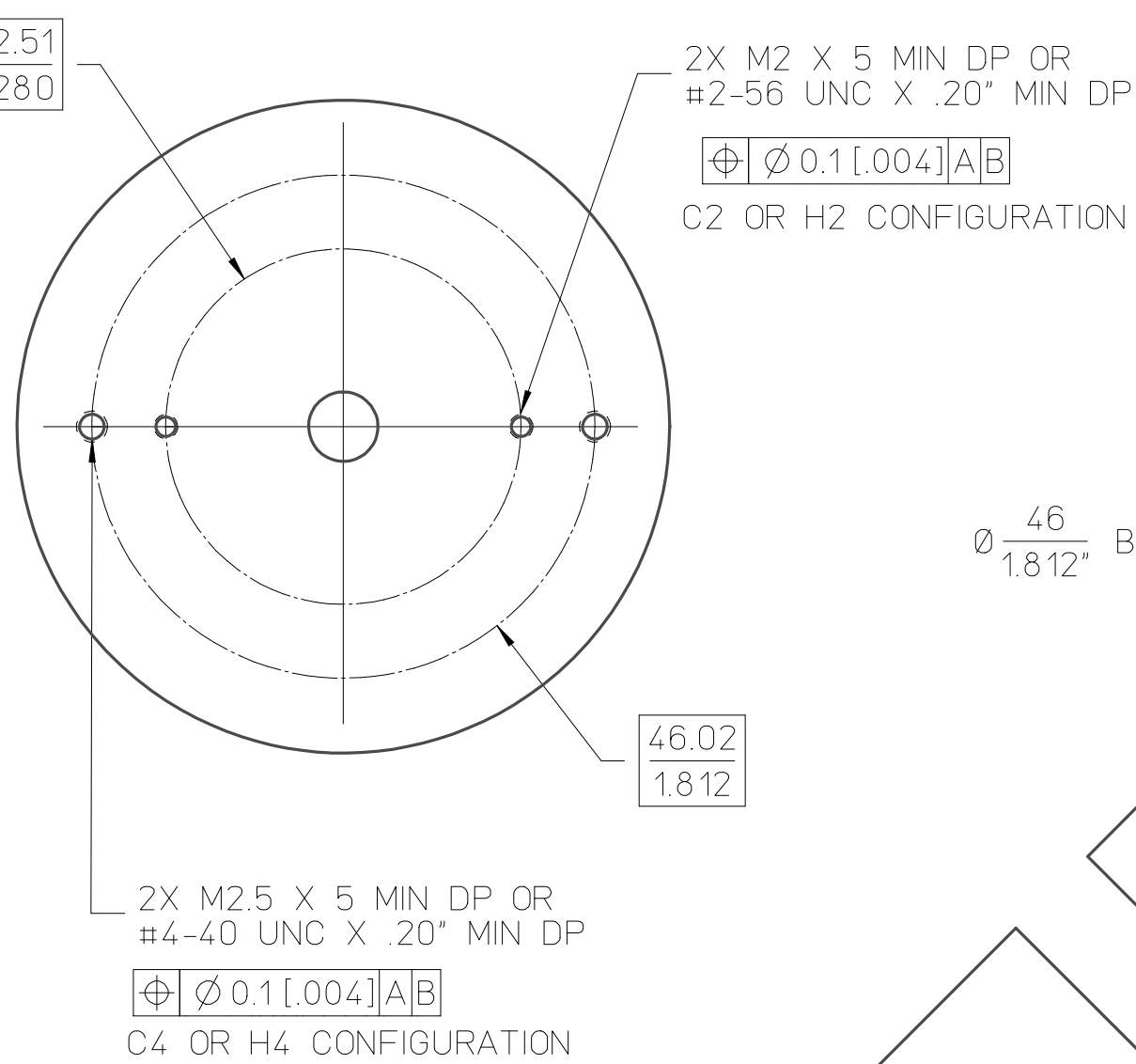
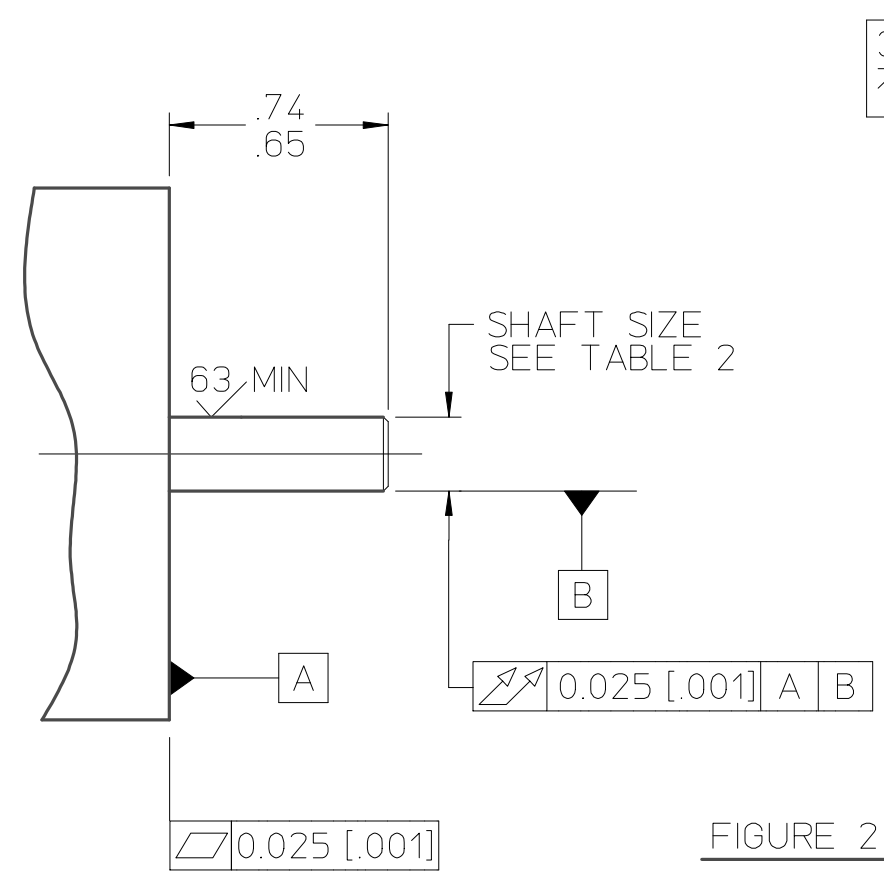
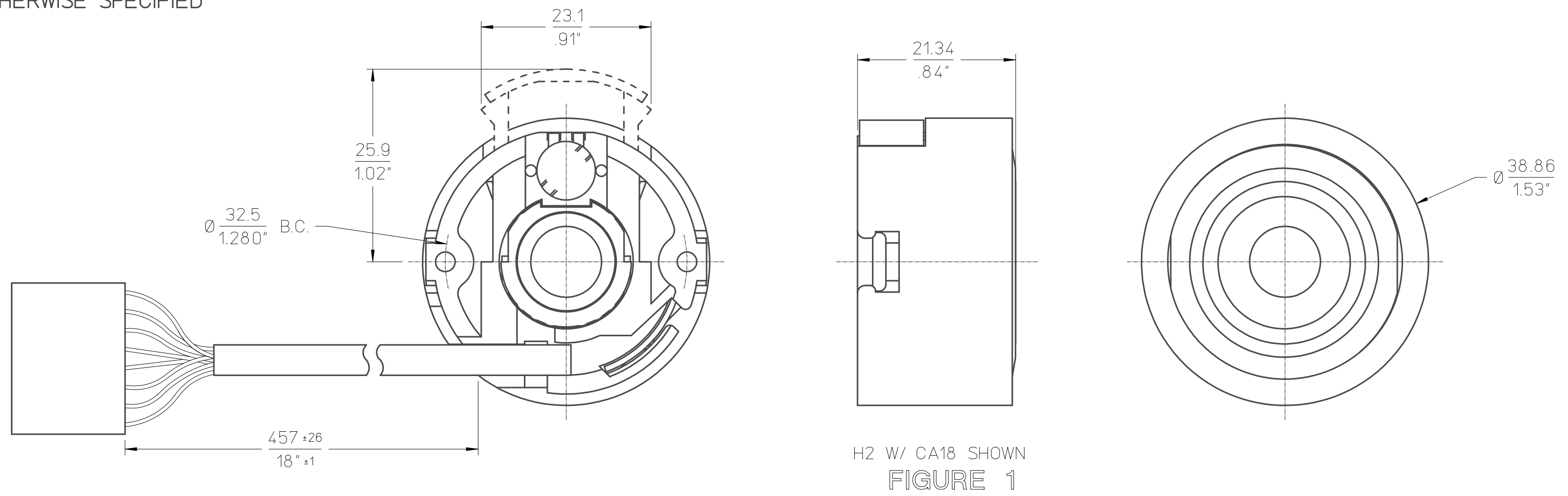
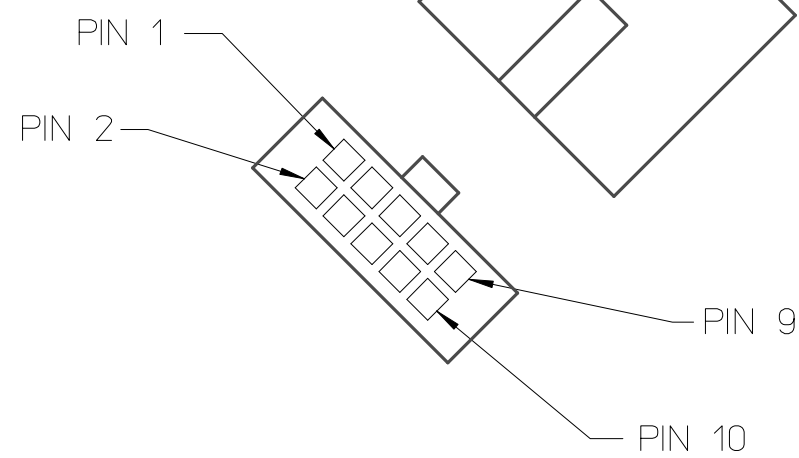

FIGURE 3



RELEASE # 39724	TEXT Initial release	 26 COROMAR DR GOLETA, CA. 93117		
This document is the property of Renco Encoders Inc. and is submitted in confidence. Disclosure, reproduction or publication without written authorization is prohibited.	DRAWN Cepeda 10/24/07 APPV'D REL'D			TITLE
MAT'L	FINISH	TOLERANCES UNLESS OTHERWISE SPECIFIED ALL DIMENSIONS ARE IN MILLIMETERS PER ISO 2768-c	SIZE FSCM NO. C 34479	DWG NO. 641499-00-A-01
THIRD ANGLE PROJECTION		SCALE NONE	THIS DWG PREPARED IN ACCORDANCE WITH: ASME Y14.5M -1994	VER [REV] SHT PAGE 2 OF 2